

LSI 58STE High Power Multichannel MMDS Transmitter

The Loma Scientific International LSI 58STE high power MMDS transmitter provides a low cost method for delivering multiple channel wireless cable television signals and programming to rural cities, small communities, college campuses and military installations, etc.

The LSI 58STE supports a variety of channel arrangements for any licensed frequency bands. Blocks of wireless cable frequencies are typically available throughout the world in the range of 2.0 to 2.7GHz.

In the US, the Federal Communications Commission (FCC) originally set aside frequencies from 2500 to 2686MHz establishing rules for MDS and ITFS as outlined in CFR 47 Part 21-K and 74-I. In countries following US frequency standards, systems may be deployed similarly as authorized by their local government agencies.

The LSI 58STE incorporates an upconverter and amplifier system that is compact and ultralinear. It accepts superband VHF (IF) signal frequencies, converts and amplifies them to the proper S-band frequency block (RF), making them available for broadcast transmission by industry proven antenna/transmission line components. With a typical high gain omnidirectional antenna, the LSI 58STE will provide radial coverage of up to 15km or more. An even greater geographical distance is possible using directional antenna(s). The LSI 58STE is compatible with all cable industry Pay TV encoding equipment. Also, receive sites with standard downconverter and decoding components can be directly interfaced with cable ready television sets or MDU distribution systems.

The LSI 58STE provides the maximum value to the customer. It offers high performance and increased reliability (MTTF) at low cost. It utilizes modular RF components and wideband RF power amplification leading to ease of customer operation, greater geographical coverage, and a potential for increase in revenues.



Features

- ❖ High power linearized amplification providing excellent analog CTB (digital ACPR)
- ❖ High reliability design with straightforward operation and easy setup
- ❖ Wideband block upconversion simplifies channel selection
- ❖ IF (VHF) multiplexing eliminates the need for RF (microwave) channel combiners
- ❖ Low cost per channel; expandable to 31+ channels
- ❖ Modular components in a space saving compact chassis
- ❖ Front panel RF (SMA) test point and forward/reverse power meter
- ❖ Capable of serving analog "free to air", PAY TV and digital video (TV) applications



LSI 58STE Rear Panel View

Options

- Redundancy Systems
- Dual Transmitter/Antenna
- Digital BRS (CFR 47 Part 27-M)
- HRC Phaselock Headends
- Pay TV Encryption Equipment
- Remote Telemetry/Control
- 120/220VAC or Universal AC



Minimum Performance and General Specifications

LSI 58STE High Power Multichannel MMDS Transmitter

Input Format			
Analog		NTSC, PAL, etc.	
Digital		QPSK, QAM, VSB, etc.	Note 1
RF Input/Output Specifications			
Input Frequency		222~408MHz	
Output Frequency		2.500~2.686GHz	Note 2
Input Level		-10dBm per channel typical	
		-20dBm per channel minimum	Note 3
Output Level		+30dBm per channel @ 16 chs	
		+33dBm per channel @ 8 chs	
Input Impedance		75ohm unbalanced, BNC jack	
Output Impedance		50ohm unbalanced, N jack	
Carrier to Noise Ratio (CNR)		50dB	
Signal to Noise Ratio (SNR)		55dB	
Spurious Products		-60dBc	
Third Order Intercept (IP3)		+68dBm (typical)	
Composite Triple Beat Distortion (CTB)		-50dBc unmodulated carriers	
		-55dBc with modulation	
Local Oscillator Frequency		2278MHz (see final test data)	
Normal Operating Temperature		+10 to +40 Degrees C	
Altitude		8,000 feet	
Relative Humidity		up to 90%, non-condensing	
AC Inlet Plug IEC connector		4 Amps (typ) @ 120VAC	
AC Power Consumption		400W (typ), 500W (max)	
Mechanical Dimensions		6.97"H x 19.00"W x 24.35"D	
Weight (120VAC Input)		37 pounds	

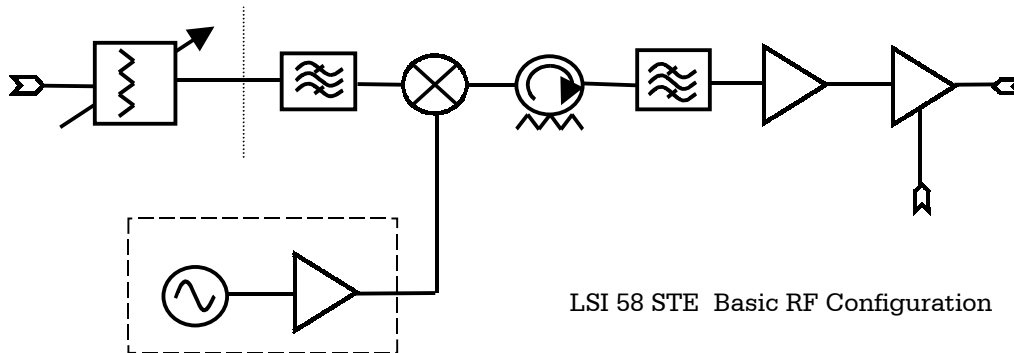

Specifications are subject to change

Notes

1. Notify sales for digital requirement(s).
2. Other frequencies are available.
3. Contact sales for other input levels.

www.lomasci.com
sales@lomasci.com
 (310) 539-8655
 fax (310) 539-8634